

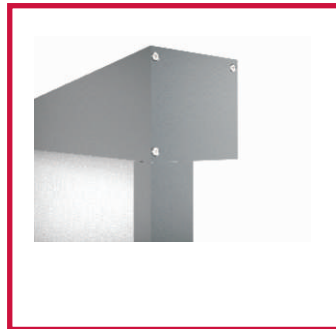

Screenener

-product card



Screenener 110 ZIP



Screenener 110



SPECIFICATION

- The main purpose of external ZIP screener shades is to gently filter sunlight, provide privacy, reduce glare, protect floors and furniture from the sun (UV fading) and reduce external heat. In addition, zip screening is an excellent barrier against strong wind gusts, insects and pollution.
- The frame of the roller blind is made from extruded aluminium and can be powder coated in any RAL colour.
- Cassette can be externally mounted to the frame of the construction.
- The ZIP mechanism and a PVC guide guarantee that the fabric stays still in the side guides.
- Remotely controlled electric wired or radio motor.
- The roller blind can be only installed vertically.
- A wide range of fabric colours.

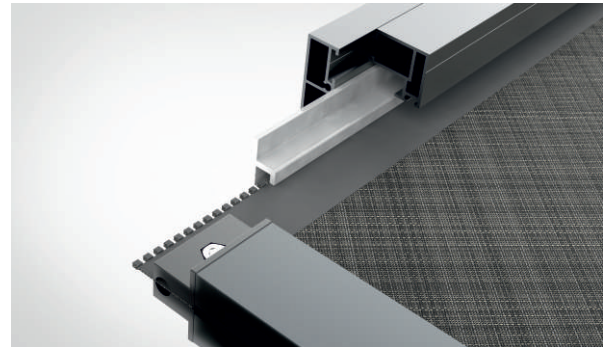
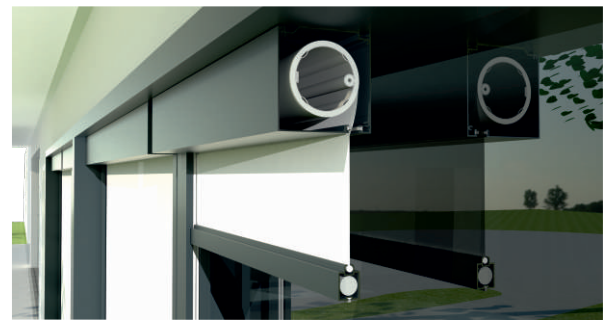

5
YEARS
WARRANTY



COLOURS

CONSTRUCTION



9010ST
Colour cream-white
similar to RAL9010



9007
Colour silver-metallic
similar to RAL9006



7016ST
Colour anthracite-metallic
similar to RAL 7016

ADDITIONAL COLOURS



Any colour from the
RAL palette
(extra charge + 10%)



Wood-like varnish
(extra charge + 25%)

FABRIC



Colour_002002



Colour_008008



Colour_003003



Colour_033033



Colour_008007



Colour_007007



Colour_001001



Colour_001010



Colour_011011



Colour_010011



Colour_010010

The product complies with the following provisions that govern implementation of directives of the European Parliament and of the Council, providing that harmonized standards and or technical documents listed below have been applied:
 PN - EN 13561 + A1: 2010 - EXTERNAL BLINDS - operational requirements and safety, according to the norm;
 PN - EN 1932: 2013 - 09 - EXTERNAL BLINDS / ROLLER SCREEN / RESISTANCE TO WIND PRESSURE - BY RESEARCH METHODS;
 WIND CLASS - 3.

wind class 3



SCREENER 110 ZIP

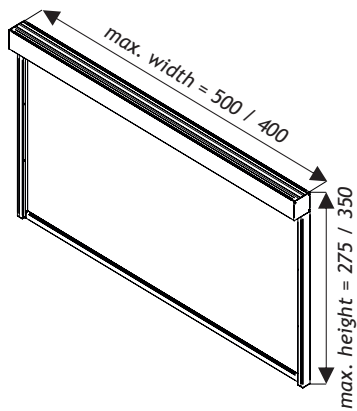

CASSETTE DIMENSIONS

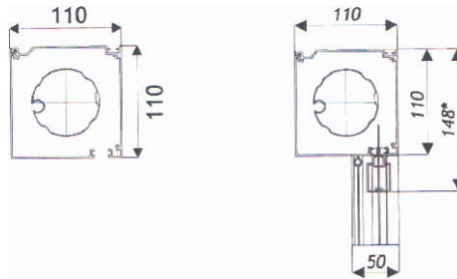

MAXIMUM DIMENSIONS

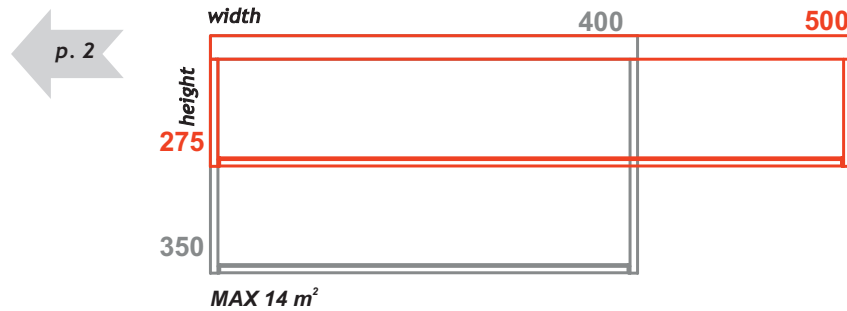

SCREENER 110

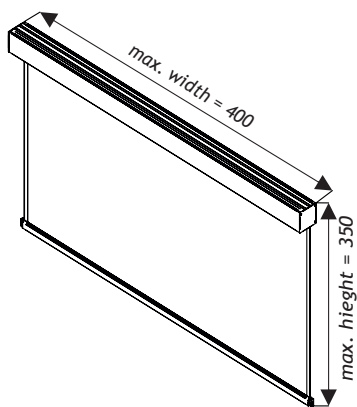

CASSETTE DIMENSIONS

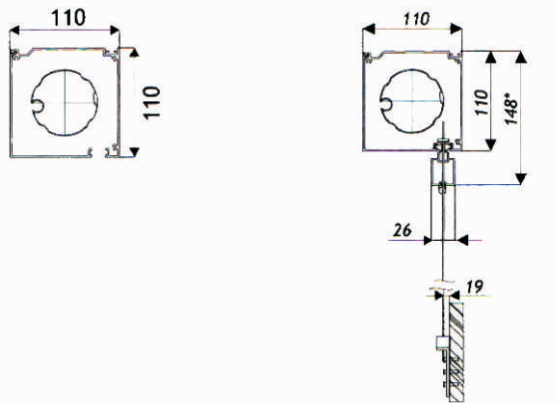

MAXIMUM DIMENSIONS

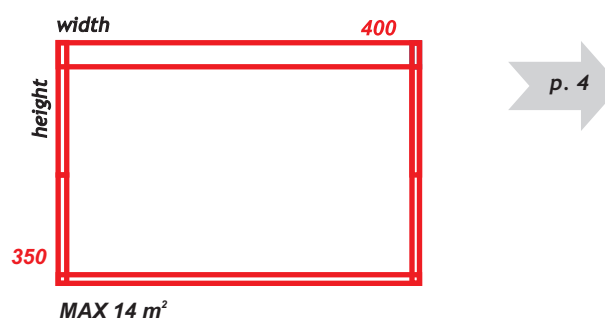



SPECIFICATION

- The main purpose of external screen shades is to gently filter sunlight, provide privacy, reduce glare, protect floors and furniture from the sun (UV fading) and reduce external heat.
- The frame of the roller blind is made from extruded aluminium and can be powder coated in any RAL colour.
- Cassette can be externally mounted to the frame of the construction.
- Remotely controlled electric wired or radio motor.
- Fabric guided by a cord.
- The roller blind can be only installed vertically.
- A wide range of fabric colours.



5
YEARS
WARRANTY



COLOURS

CONSTRUCTION



9010ST
Colour cream-white
similar to RAL9010



9007
Colour silver-metallic
similar to RAL9006



7016ST
Colour anthracite-
metallic similar to RAL 7016

ADDITIONAL COLOURS



Any colour from the
RAL palette
(extra charge + 10%)



Wood-like varnish
(extra charge + 25%)

FABRIC



Colour_002002



Colour_008008



Colour_003003



Colour_033033



Colour_008007



Colour_007007



Colour_001001



Colour_001010



Colour_001011



Colour_010011



Colour_010010

The product complies with the following provisions that govern implementation of directives of the European Parliament and of the Council, providing that harmonized standards and or technical documents listed below have been applied:
PN - EN 13561 + A1: 2010 - EXTERNAL BLINDS - operational requirements and safety, according to the norm;
PN - EN 1932: 2013 - 09 - EXTERNAL BLINDS / ROLLER SCREEN / RESISTANCE TO WIND PRESSURE - BY RESEARCH METHODS;
WIND CLASS - 3.

wind class 3



Fabrics	description	description
Serge 600 / Copaco / Aeroflex	outside / inside	525 g/m ²
Soltis 86	outside / inside	380 g/m ²
Soltis 88	outside / inside	360 g/m ²
Soltis 92	outside / inside	420 g/m ²
Soltis 92 B	outside / inside / blackout	420 g/m ²
Soltis 96	outside / inside	400 g/m ²
Soltis W 96	outside / inside	620 g/m ²
Soltis 99	inside	290 g/m ²
Soltis B 99	inside	290 g/m ²
Sunworker	outside / inside	300 g/m ²
Sunworker Open	outside / inside	360 g/m ²
Sunworker Opaque	outside / inside	450 g/m ²

Motors

Wired motors **somfy.**

SOMFY 10 Nm/ 17 rotations/ min

SOMFY 20 Nm/ 17 rotations/ min

CRANK HANDLE - MANUAL CONTROL

Radio motors **somfy. RTS**

Somfy ALTUS RTS 10 Nm/ 12 rotations/ min

Somfy ALTUS RTS 20 Nm/ 12 rotations/ min

Somfy ALTUS RTS 10 Nm/ 17 rotations/ min

Somfy ALTUS RTS 20 Nm/ 17 rotations/ min

Radio motors **somfy. IO**

Somfy ALTUS RS IO 10 Nm/ 12 rotations/ min (wind sensor not available)

Somfy ALTUS RS IO 20 Nm/ 12 rotations/ min (wind sensor not available)

Somfy MAESTRIA IO 10/32 (wind sensor available on request)

Somfy MAESTRIA IO 15/32 (wind sensor available on request)

Controls TELECO

Radio control unit 230 V for 1 motor

Radio control unit up to 4 motors (optional sensor: wind)

42 channel remote control, black/white

Remote controls RTS

SITUO 1 RTS remote control, single-channel

SITUO 5 RTS remote control, five-channel

TELIS 1 SOLIRIS RTS remote control, single-channel with solar sensor support

TELIS 4 SOLIRIS RTS remote control, five-channel with solar sensor support

TELIS 16 RTS remote control, sixteen-channel

Remote controls IO

SITUO 1 IO remote control, single-channel

SITUO 5 IO remote control, five-channel

NINA IO remote control

NINA TIMER IO remote control

Smartphone control

TAHOMA SOMFY

CONEXON IO

CONEXON RTS

DAISY TELECO

Weather sensors

Wind EOLIS SENSOR RTS for radio engines (white)

Wind-Solar SOLIRIS SENSOR RTS for radio engines (white)

Wind TELECO

Infrared heaters

power

Infrared heater GRI – controlled by a switch with a LOW GLARE emitter that generates less light, water-tight class IP65, colour: white or black, usually controlled by a wall switch. For external use.

1,5 kW

Infrared heater GR2 IR – a infrared heater with a built-in infrared receiver, remote control and a LOW GLARE emitter that releases less light. Water-tight class IP65, colour white or black, controlled by an infrared remote control (in set). For external use.

1,5 kW

Infrared heater Gr1 + receiver Somfy RTS 2 kW

Infrared heater Gr1 + receiver Somfy IO 2 kW

Additional infrared remote control

Radio receivers for infrared heaters GRI

Somfy RTS receiver

Enables to operation of the infrared heater by remote control in range of on/off. Works with TELIS remote control.

For the single infrared heater max. power 2 kW

Somfy RTS MODULIS Receiver

Enables to operation of the infrared heater by remote control in range of on/off and regulate the intensity of heat in range from 0% to 100%. Works with remote control TELIS MODULIS (recommended) and TELIS remote control.

For of 1 to 2 infrared heaters of total power 3 kW

TELECO ON/OFF Receiver up to 1-2 pcs infrared heater 3kW

For of 1 to 2 infrared heaters of total power 3 kW

SOMFY IO ON/OFF Receiver for 1 infrared heater 2kW

For the single infrared heater max. power 2 kW



Contact:

phone: +48 607 189 400

+48 502 342 842

e-mail: export@tarasola.com

www.tarasola.com